



Alban Giacomo SpA

COMPANY WITH
QUALITY SYSTEM
CERTIFIED BY DNV
= ISO 9001 =

TECHNICAL MANUAL

LIFT & SLIDE

Climatech Imago 78_{mm}

- 78x74 mm sections system.
- Gasket, external and internal, vertical - lower: bulb-type with vulcanized corner in EPDM.
- Internal side EPDM gasket for covering milling.
- Embedded top guide and pultruded fiberglass threshold.
- 28 mm distance between the sashes.
- Uni-V central point with aluminium anti-thrust beak and wooden covering parts.
- Layout E realised with symmetric central point with aluminium pin holder profile and caps to close the compartment.
- 27,5 mm backset lock.

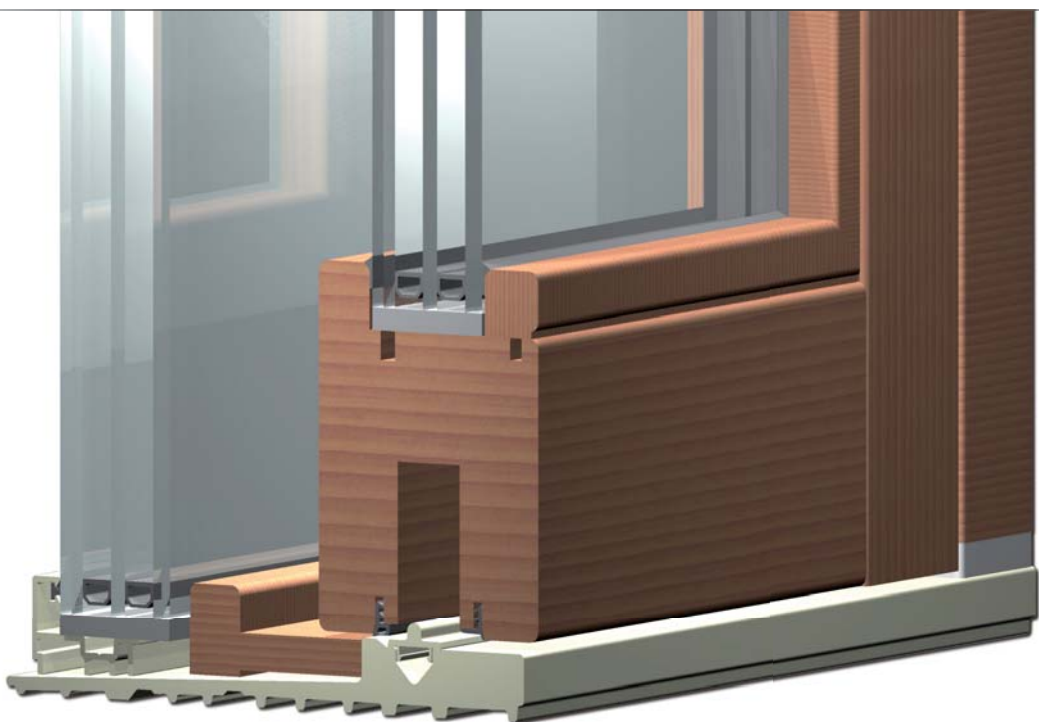

INDEX

Hardware layout - sash part	4
Hardware layout- frame part	5
Key legend and abbreviations	6
Dimensional limits	6
Sliding sashes width calculation	6
Sliding sashes height calculation	7
Horizontal section- Layout A - lenght calculation	8
Wood detailing: sliding sash horizontal section - Layout A	10
Wood detailing: central point and fixed sash horizontal section- Layout A	11
Vertical section (A-A) (B-B) - Layout A	12
Vertical section (C-C)- Layout A	13
Vertical section top point (D-D)- Layout A	14
Vertical section bottom point (E-E) - Schema A	15
Vertical section (F-F)- Layout A	16
Wood detailing: vertical section- Layout A	17
Central point horizontal section with coaxial sashes- Layout E	18
Wood detailing: central point horizontal section - Layout E	18
Central profile and beak on sliding sash positioning- Layout E	19
Locks hole realisation	20
Mounting carriages, lock and accessories	21
Sash assembly	22
Ventilation striker application	22
Positioning of the fixed sash glass	23
Sliding sash assembling	23
Locking pin mounting on wooden pin holder profile	24
Particular locking profile for central point with symmetric coaxial sashes	25
Frame component measurements and techniques for air-water tightness	26
Sash component measurements and techniques for air-water tightness	26



Notice of any new developments regarding accessories, assembly and work on casements shall be provided on an ongoing basis with periodic updates of this manual. We therefore recommend particular attention to publication of new versions via the www.agb.it site



Window and door manufacturers benefitting from the AGB cascading contract are required to install glass with the following minimum requirements:

Minimum thickness 33.1/12/5/10/33.1 Shatterproof

Hardware layout - sash part

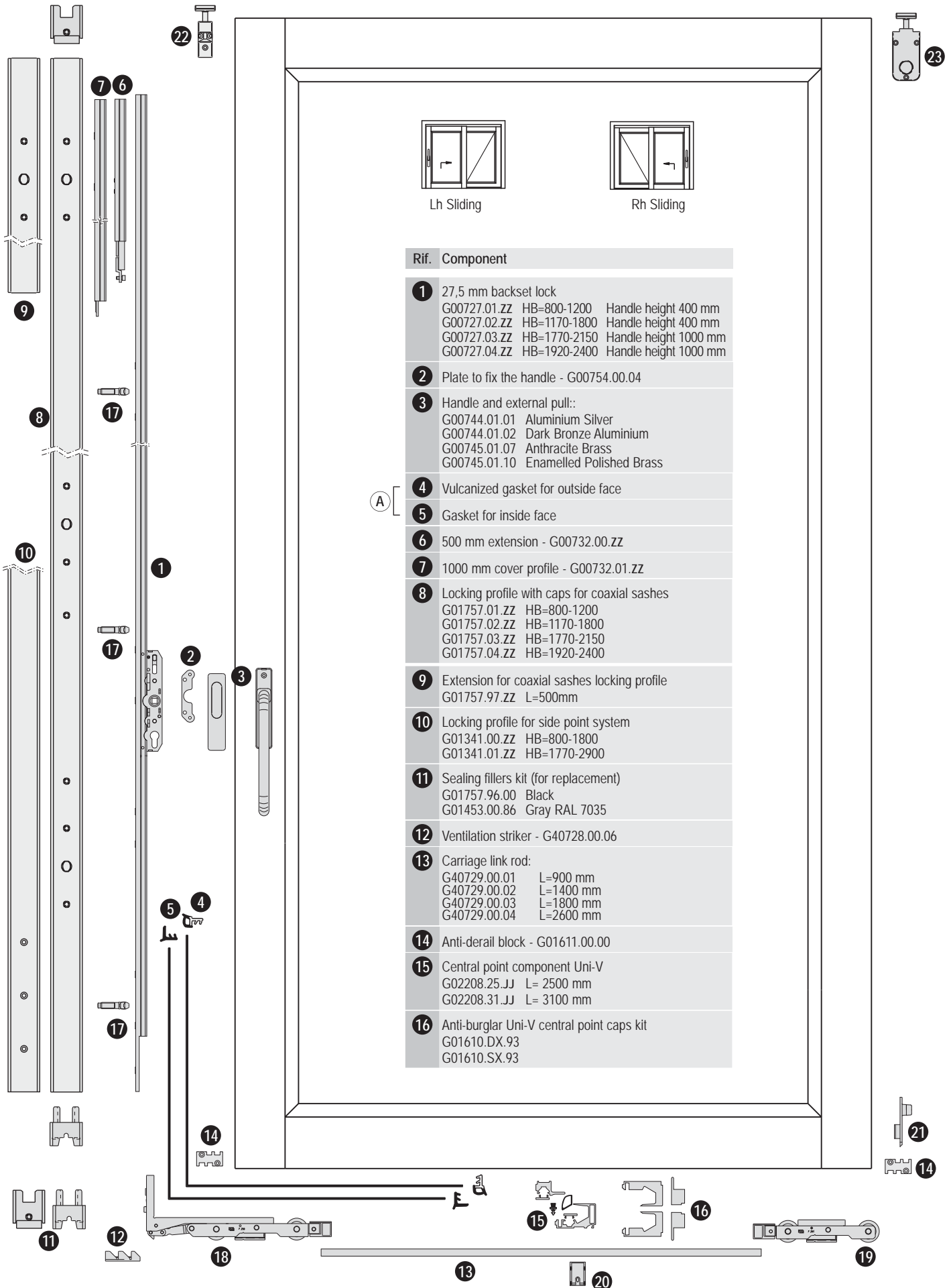

Hardware layout- frame part

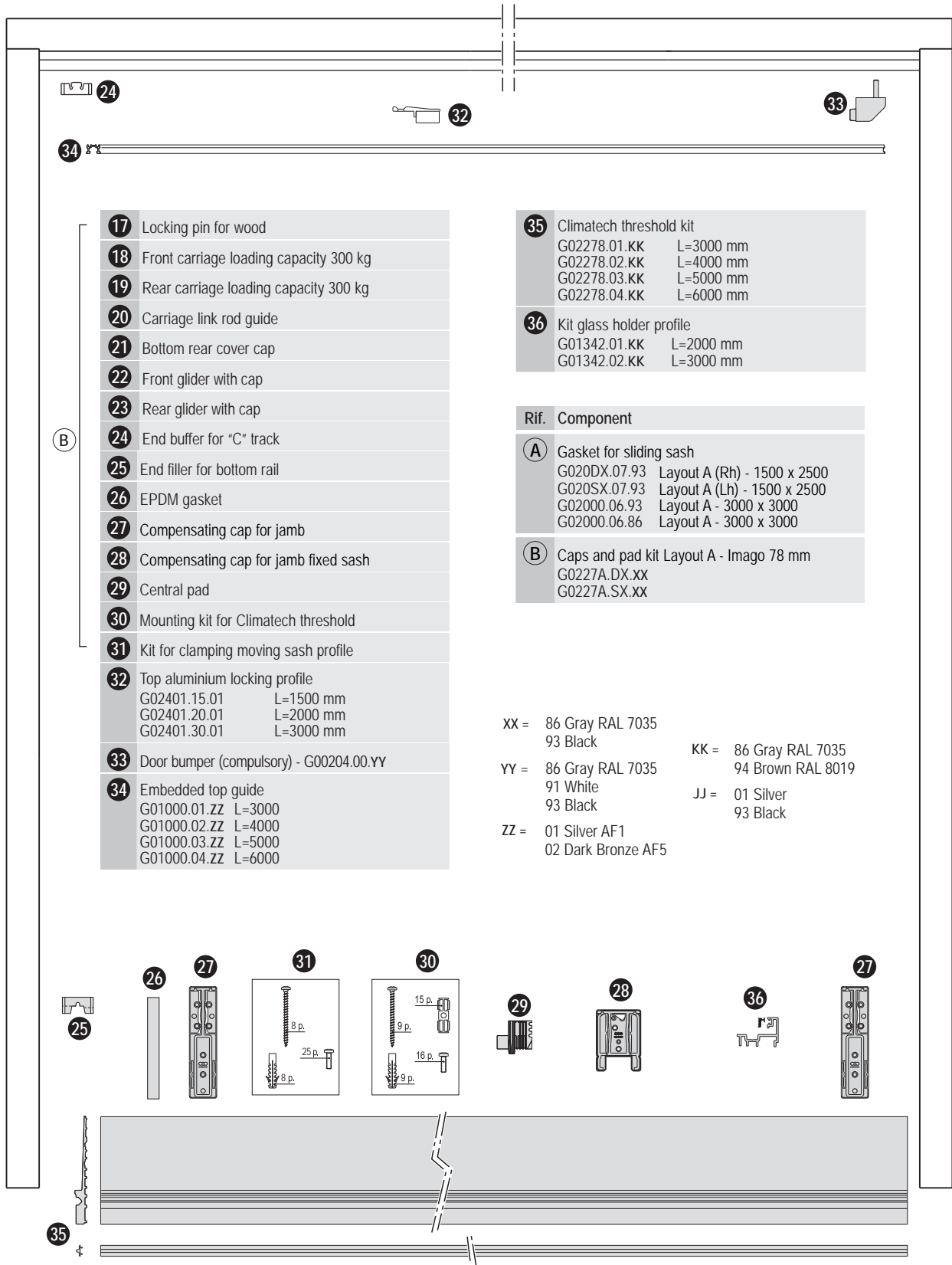

17	Locking pin for wood
18	Front carriage loading capacity 300 kg
19	Rear carriage loading capacity 300 kg
20	Carriage link rod guide
21	Bottom rear cover cap
22	Front glider with cap
23	Rear glider with cap
24	End buffer for "C" track
25	End filler for bottom rail
26	EPDM gasket
27	Compensating cap for jamb
28	Compensating cap for jamb fixed sash
29	Central pad
30	Mounting kit for Climatech threshold
31	Kit for clamping moving sash profile
32	Top aluminium locking profile G02401.15.01 L=1500 mm G02401.20.01 L=2000 mm G02401.30.01 L=3000 mm
33	Door bumper (compulsory) - G00204.00.YY
34	Embedded top guide G01000.01.ZZ L=3000 G01000.02.ZZ L=4000 G01000.03.ZZ L=5000 G01000.04.ZZ L=6000

35	Climatech threshold kit G02278.01.KK L=3000 mm G02278.02.KK L=4000 mm G02278.03.KK L=5000 mm G02278.04.KK L=6000 mm
36	Kit glass holder profile G01342.01.KK L=2000 mm G01342.02.KK L=3000 mm

Rif.	Component
A	Gasket for sliding sash G020DX.07.93 Layout A (Rh) - 1500 x 2500 G020SX.07.93 Layout A (Lh) - 1500 x 2500 G02000.06.93 Layout A - 3000 x 3000 G02000.06.86 Layout A - 3000 x 3000
B	Caps and pad kit Layout A - Imago 78 mm G0227A.DX.xx G0227A.SX.xx

XX = 86 Gray RAL 7035
93 Black
KK = 86 Gray RAL 7035
94 Brown RAL 8019
YY = 86 Gray RAL 7035
91 White
93 Black
JJ = 01 Silver
93 Black
ZZ = 01 Silver AF1
02 Dark Bronze AF5

For assembling, the following screws are necessary:						
3,5x20mm	3,5x30mm	3,5x40mm	3,5x50mm	4,5x35mm	4,5x60mm	6x120mm



Key legend and abbreviations

HB =	Door height
LB =	Rebated width
MET =	Outside frame length
SMT =	Door frame jamb thickness
SMA =	Sash jamb thickness
LBF =	Fixed rebated width
HET =	Outside frame height
H =	Component height
L =	Component length

● = Neutral silicone bead with Primer

Note: all measurements are in millimetres

Dimensional limits

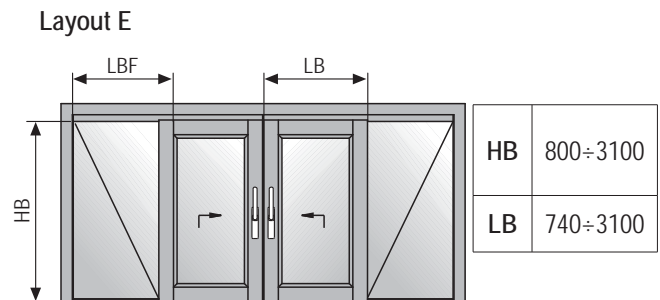
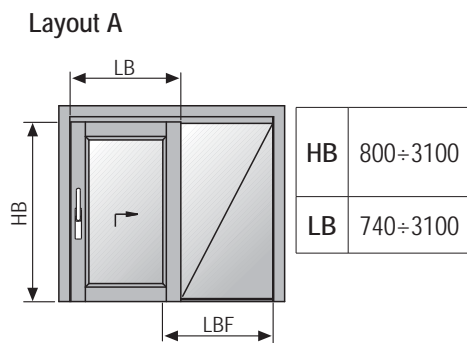

Sliding sashes width calculation

Layout A

1 fixed sash glass and 1 sliding door

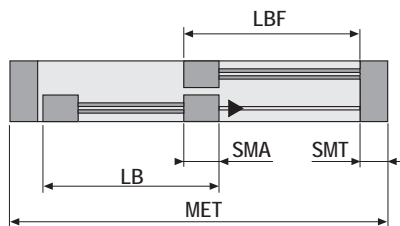

With symmetric sashes

$$LB = [MET - (2 \times SMT)] : 2 + (SMA : 2) - 5$$

E.g. $LB = [4000 - (2 \times 45)] : 2 + (74 : 2) - 5$ $LB = 1987$ mm

With asymmetric sashes

$$LB = MET - LBF - (2 \times SMT) - 5 + 74$$

E.g. $LB = 4000 - 2500 - (2 \times 45) - 5 + 74$ $LB = 1479$ mm

$$LBF = MET - LB - (2 \times SMT) - 5 + 74$$

E.g. $LBF = 4000 - 1000 - (2 \times 45) - 5 + 74$ $LBF = 2979$ mm

Layout E

2 fixed sashes glass and 2 sliding doors



With symmetric sashes

$$LB = [MET - (2 \times SMT + 5)] : 4 + SMA : 2$$

E.g. $LB = [6000 - (2 \times 45 + 5)] : 4 + 74 : 2$ $LB = 1513$ mm

With asymmetric sashes

$$LB = [MET - (2 \times SMT + 5) - (2 \times LBF)] : 2 + SMA$$

E.g. $LB = [6000 - (2 \times 45 + 5) - (2 \times 1500)] : 2 + 74$ $LB = 1526$ mm

$$LBF = [MET - (2 \times SMT + 5) - (2 \times LB)] : 2 + SMA$$

E.g. $LBF = [6000 - (2 \times 45 + 5) - (2 \times 1700)] : 2 + 74$ $LBF = 1326$ mm

Sliding sashes height calculation

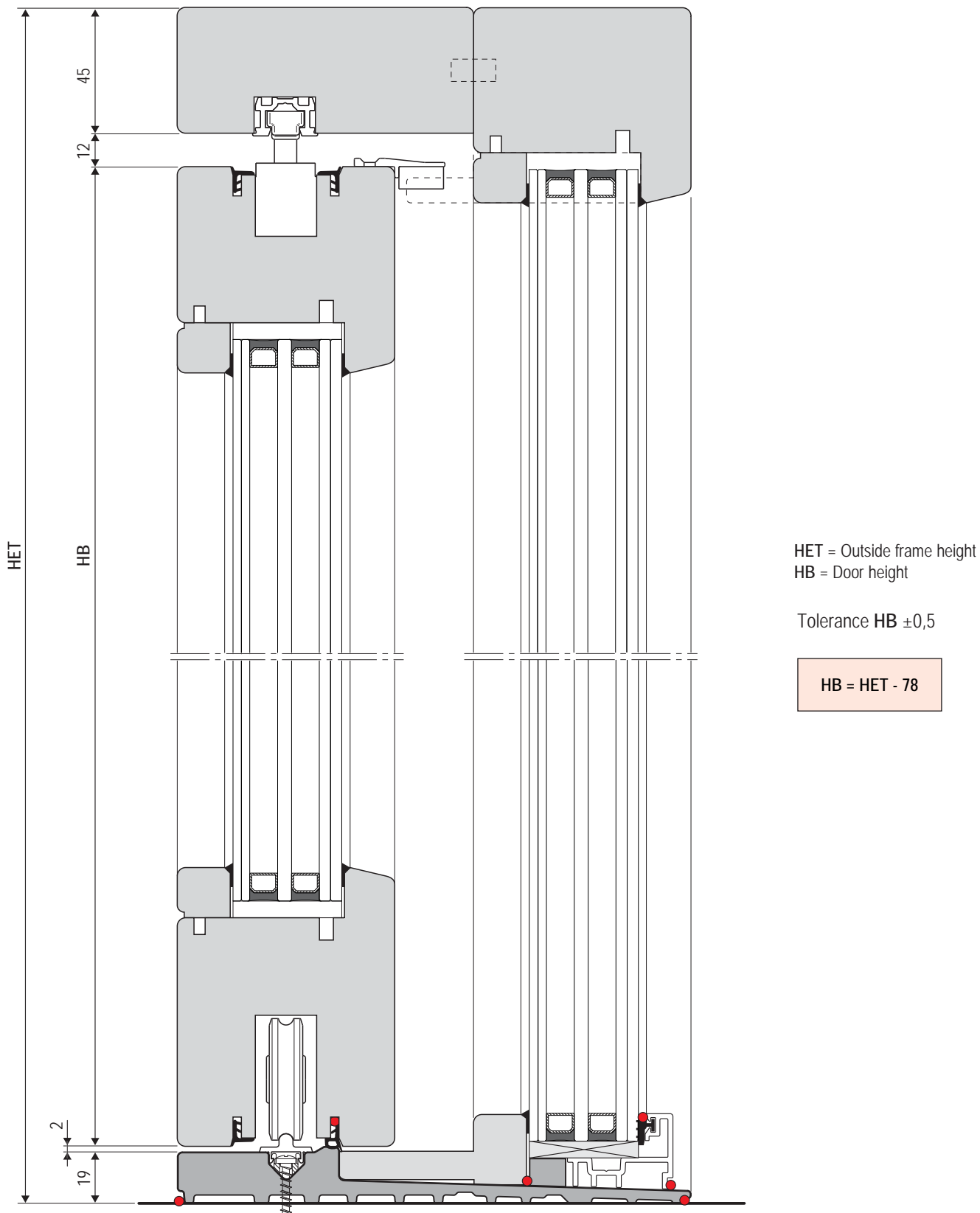

Horizontal section- Layout A - lenght calculation

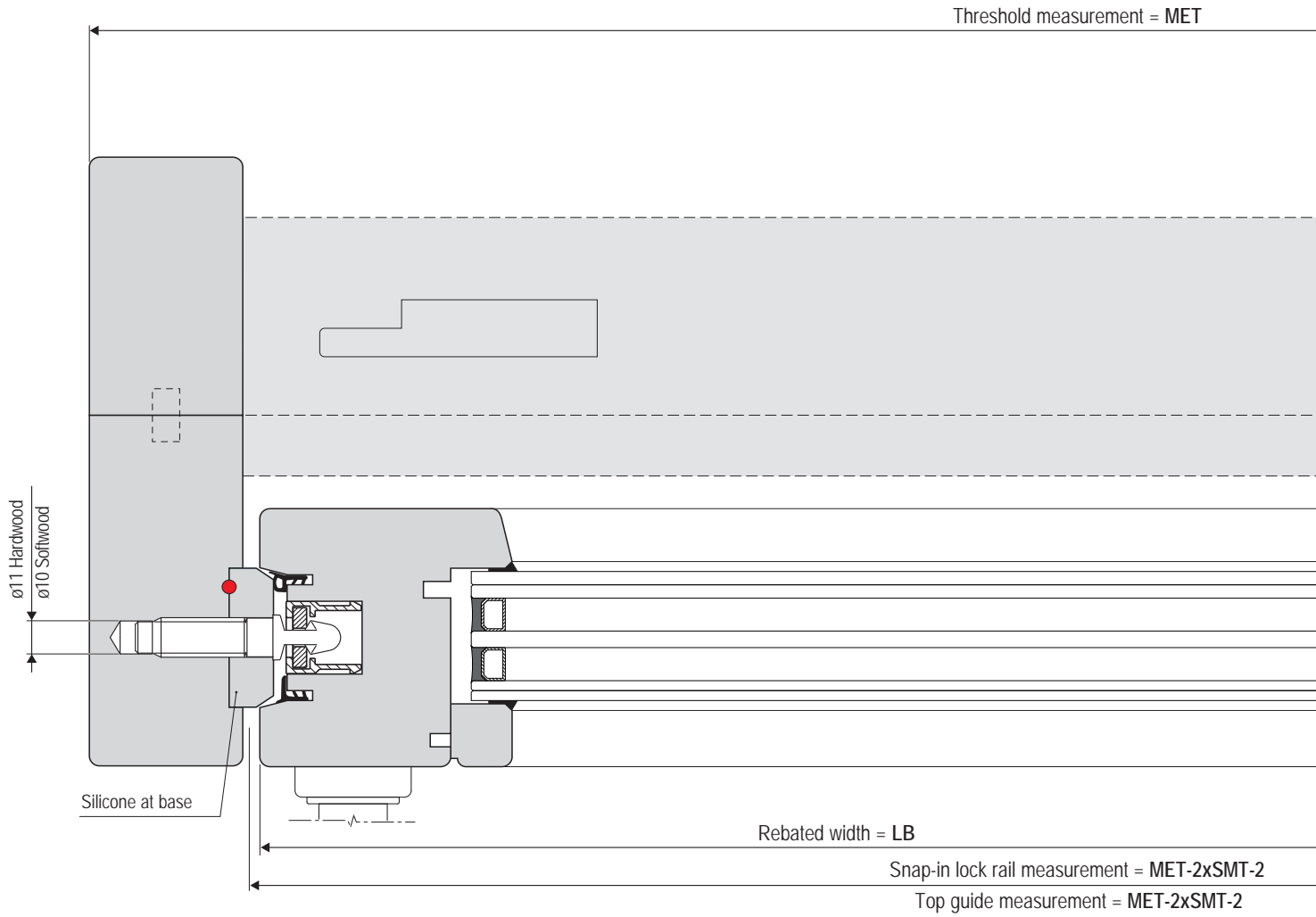

ALTERNATIVE SOLUTION WITH LOCKING PROFILE ALUMINIUM PIN HOLDER

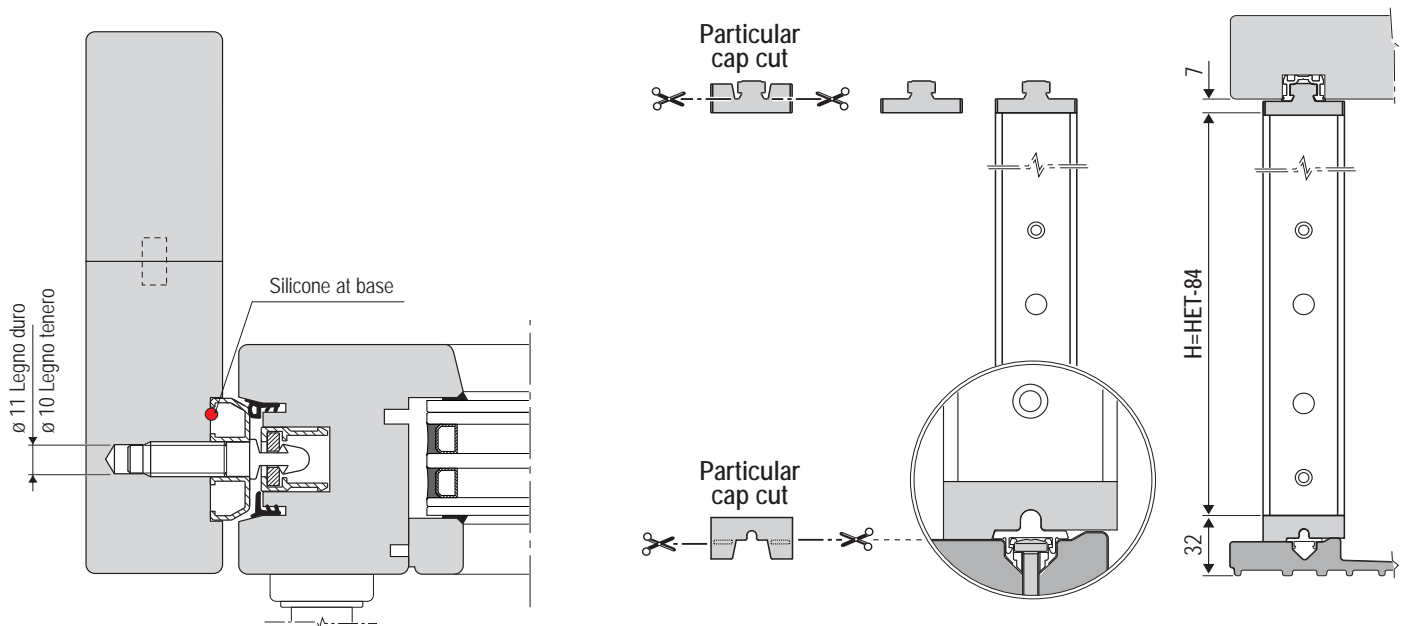

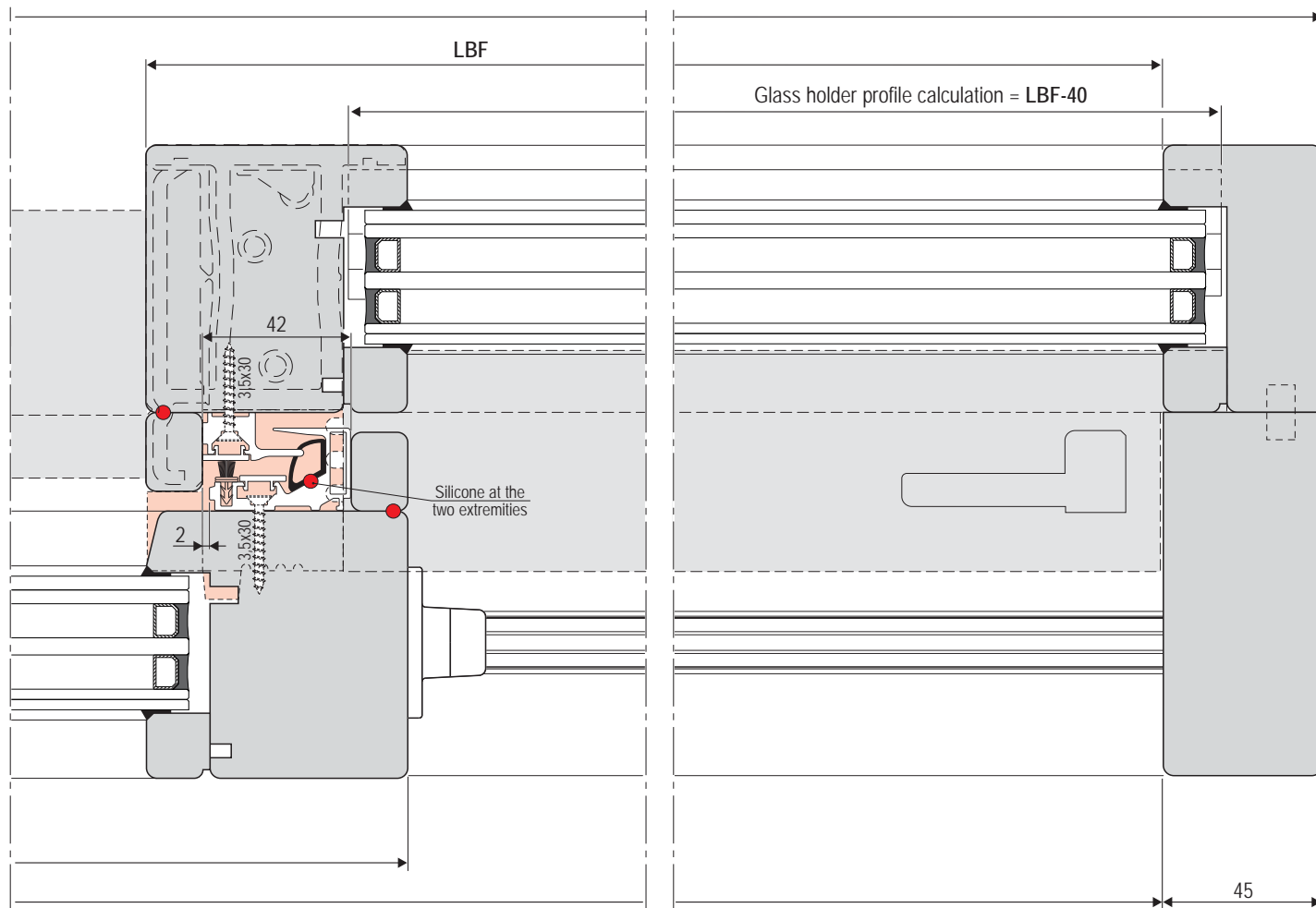

PARTICULAR COMPOSITION FOR CENTRAL POINT

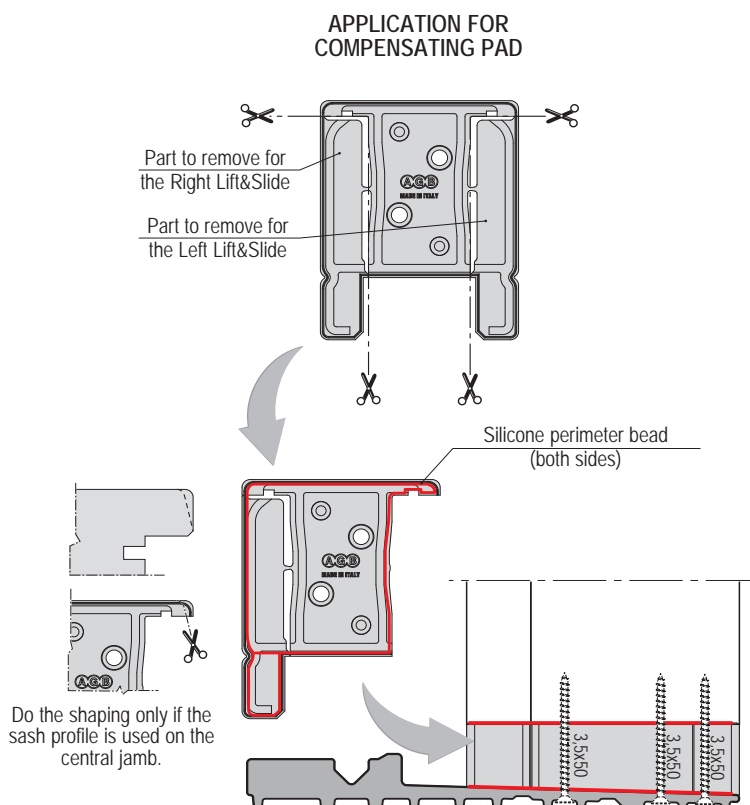
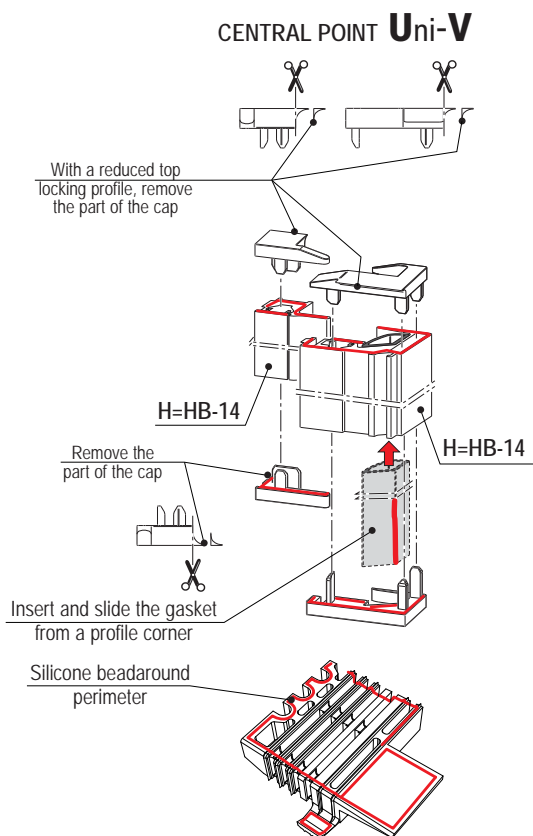

Wood detailing: sliding sash horizontal section - Layout A

Scale 1:1



The glazing bead dimensions and the lower termic profile suppose the use of a 41 mm glass shim.

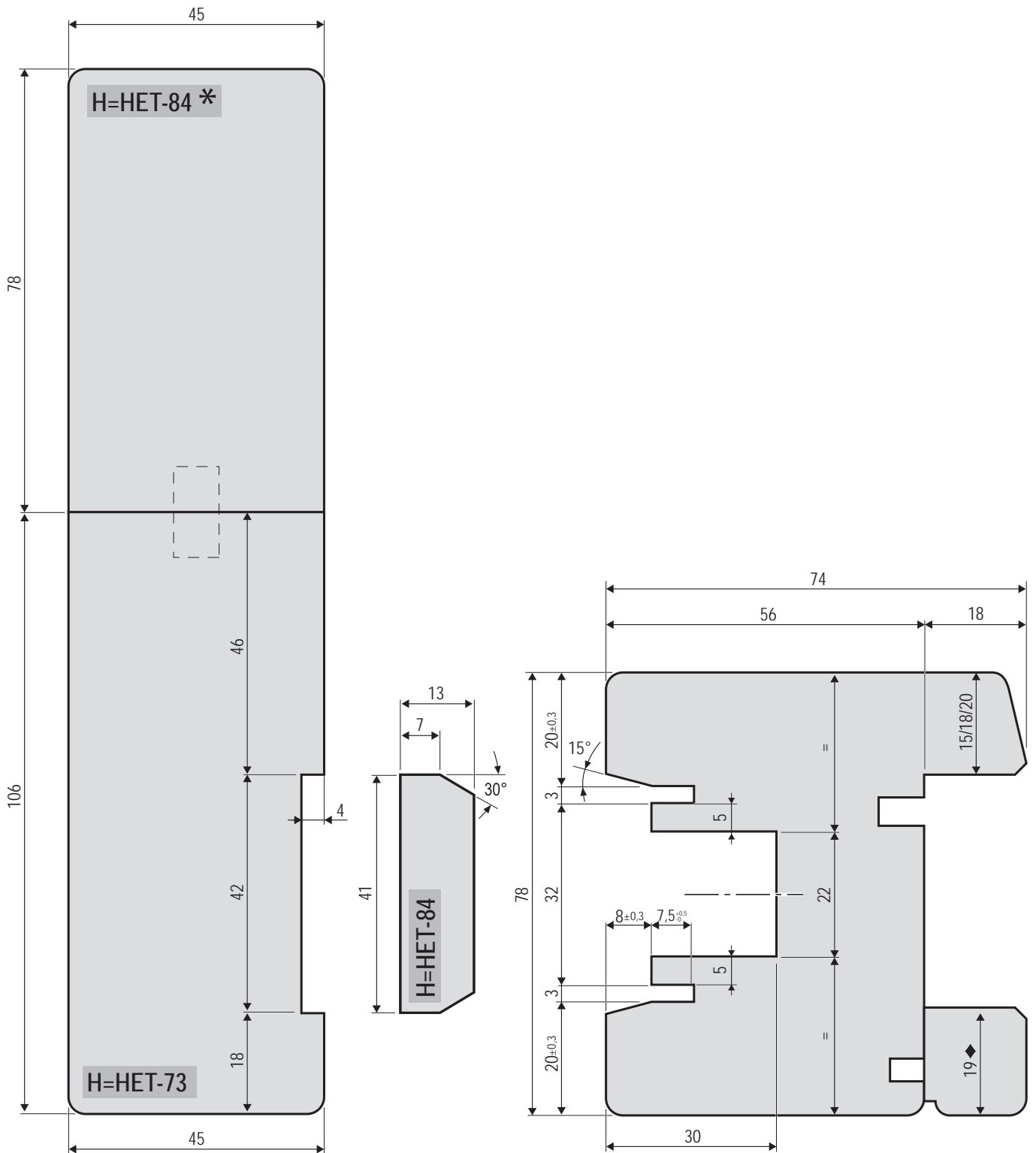

Wood detailing: central point and fixed sash horizontal section- Layout A

Scale 1:1



The glazing bead dimensions and the lower termic profile suppose the use of a 41 mm glass shim.



Pre-drill holes for the mounting screws of the compensating pad

It's possible to realize the central jamb using the sash profile (in this case the compensating pad must be adapted depending on the profile)

* Assign the top extremity to the frame transom

◆ Value calculated depending on a 18 mm external glazing bead shim

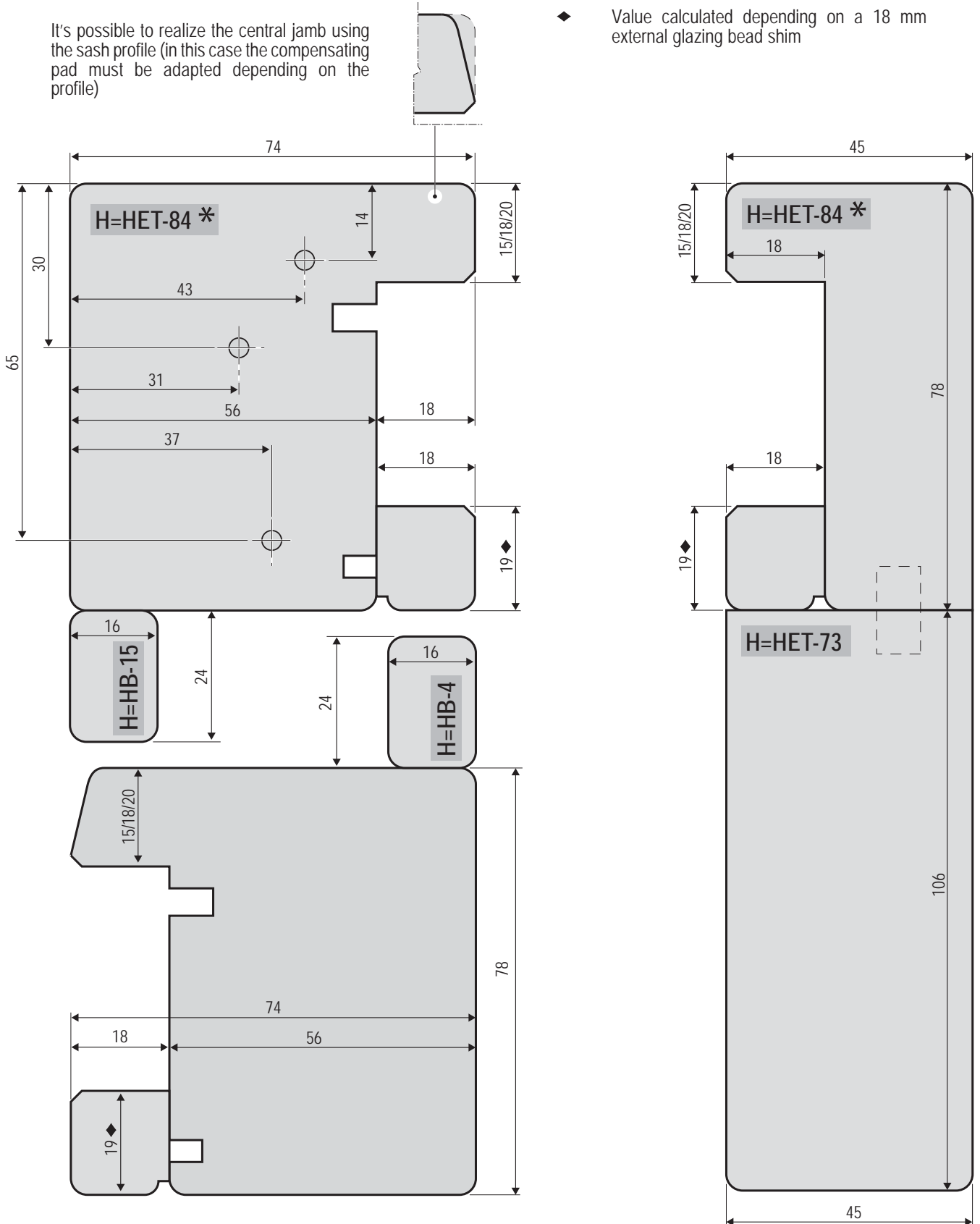

Vertical section (A-A) (B-B) - Layout A

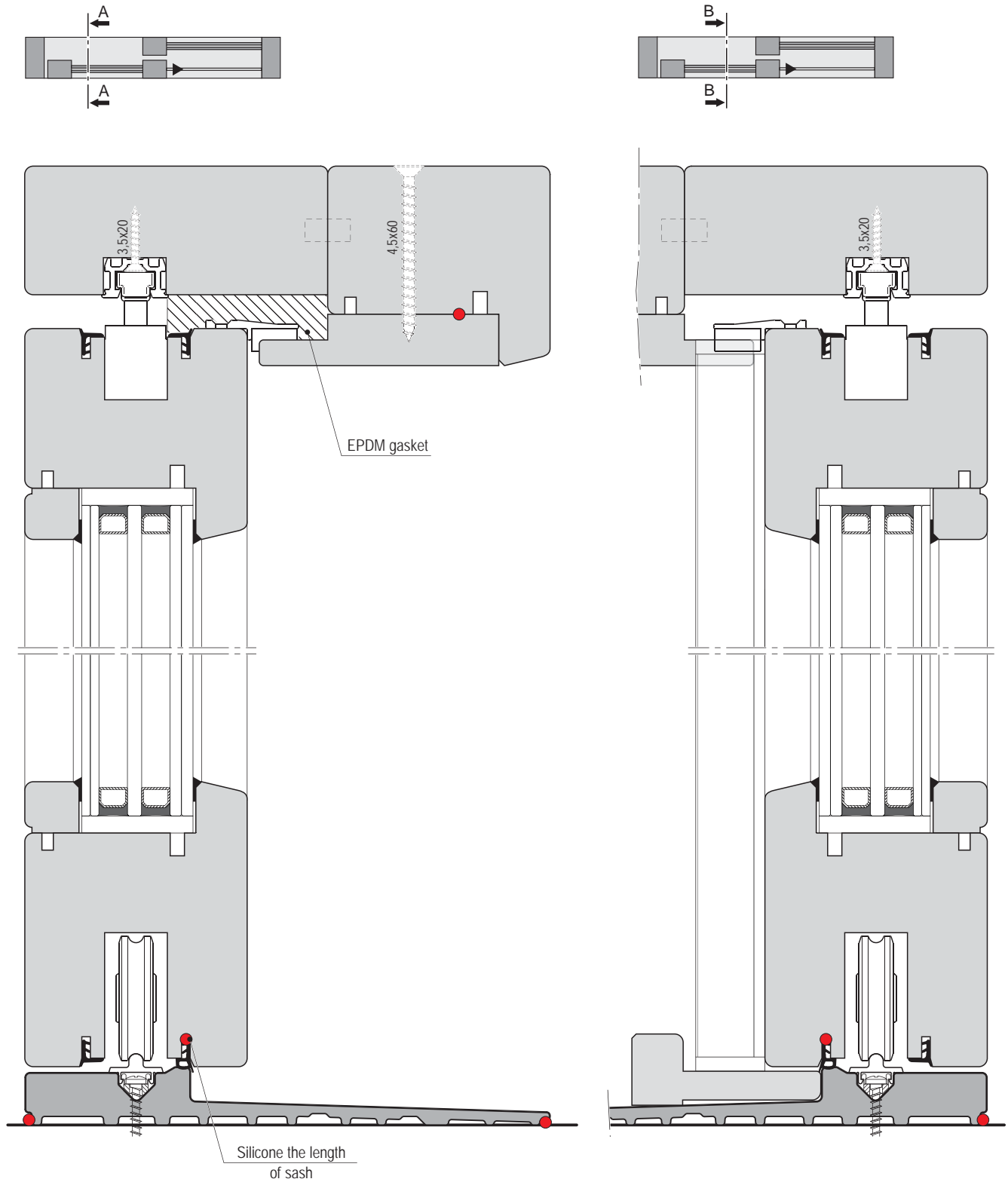

Vertical section (C-C)- Layout A

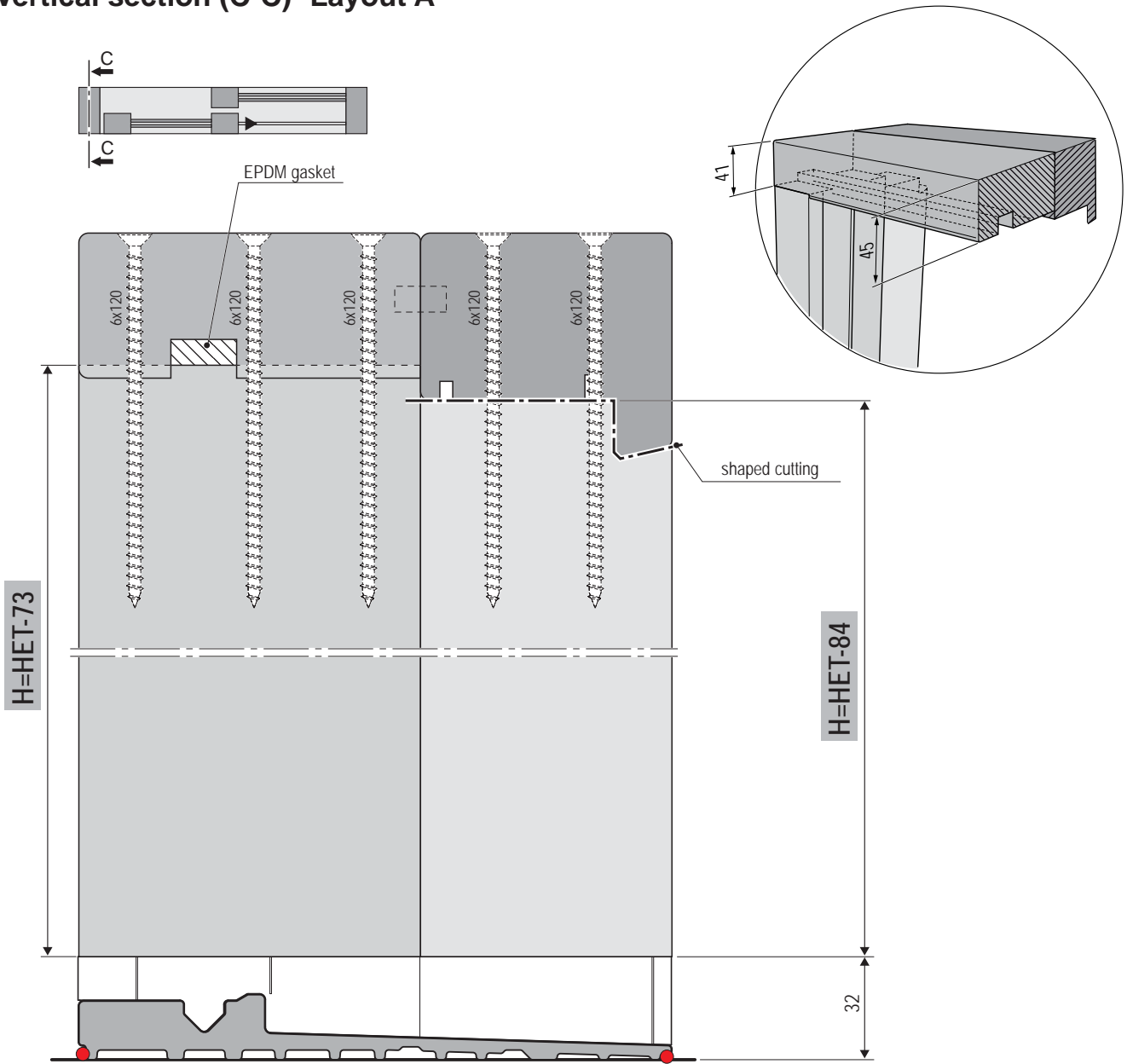

APPLICATION FOR FRAME
COMPENSATING PAD
(example of the left Lift&Slide)

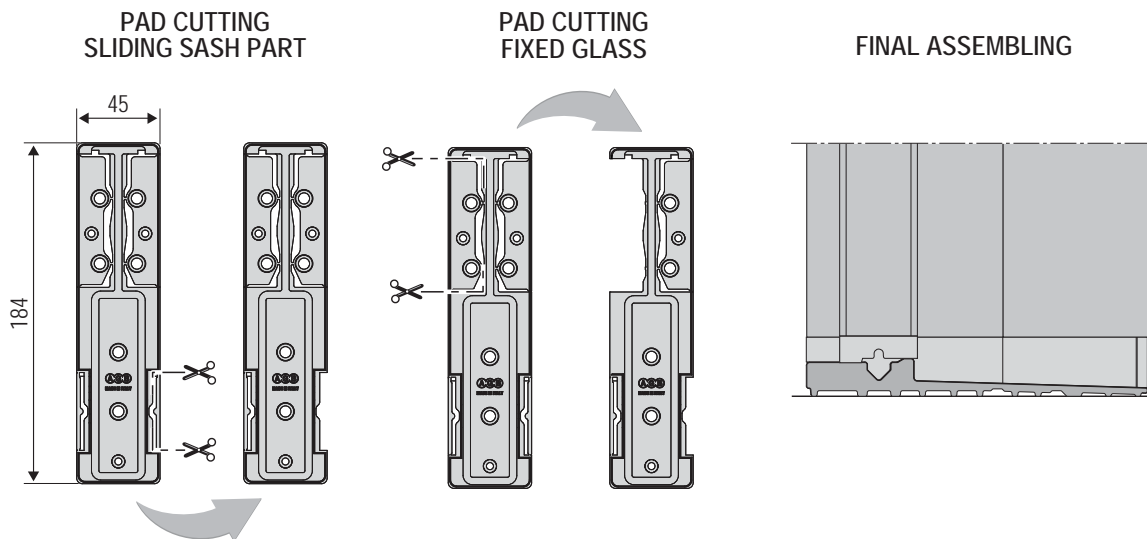

Vertical section top point (D-D)- Layout A

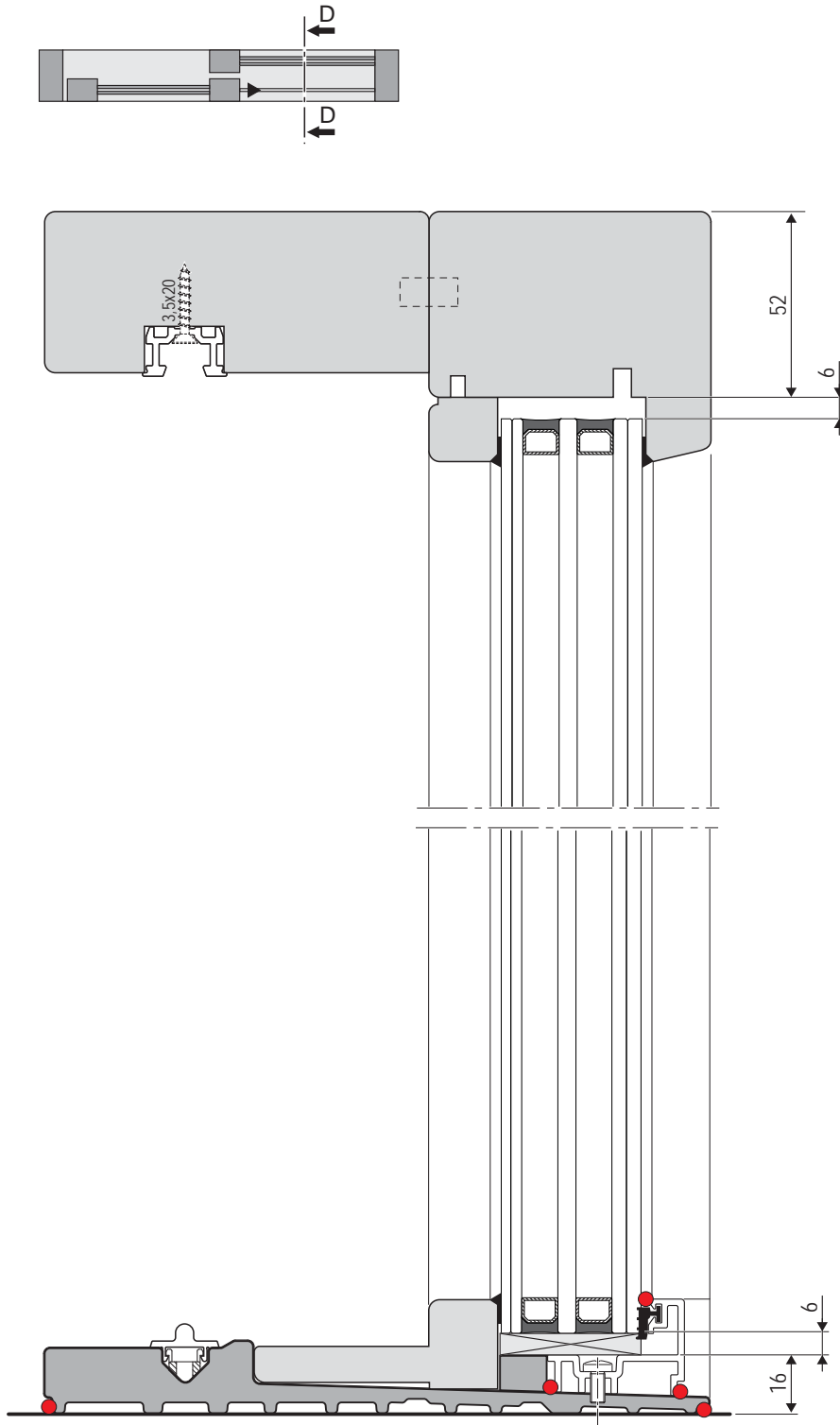

Vertical section bottom point (E-E) - Schema A

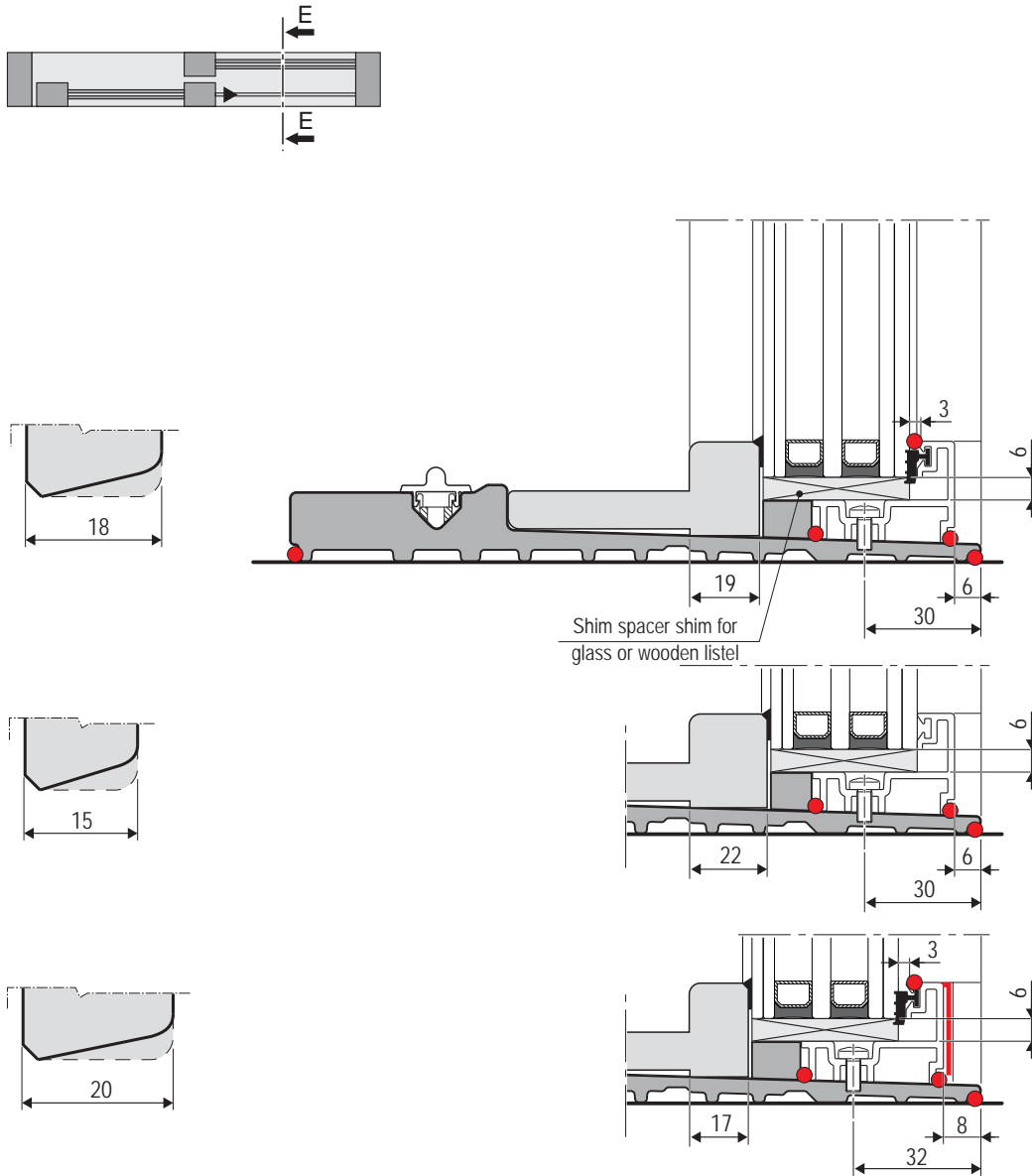

ASSEMBLING INSTRUCTIONS FOR
GLASS HOLDER PROFILE

- Insert the gasket from a corner;
- fix the glass holder profile alternating a trilobal screw and a plugs screw;
- do a silicone bead for all the profile length;
- do a silicone bead on the specific part of the compensating pad.

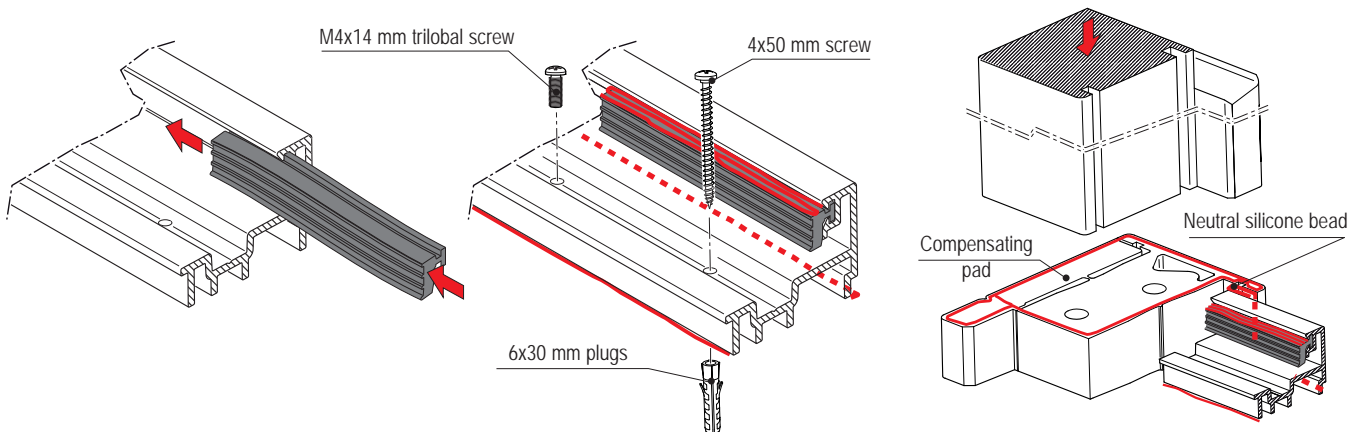

Vertical section (F-F)- Layout A

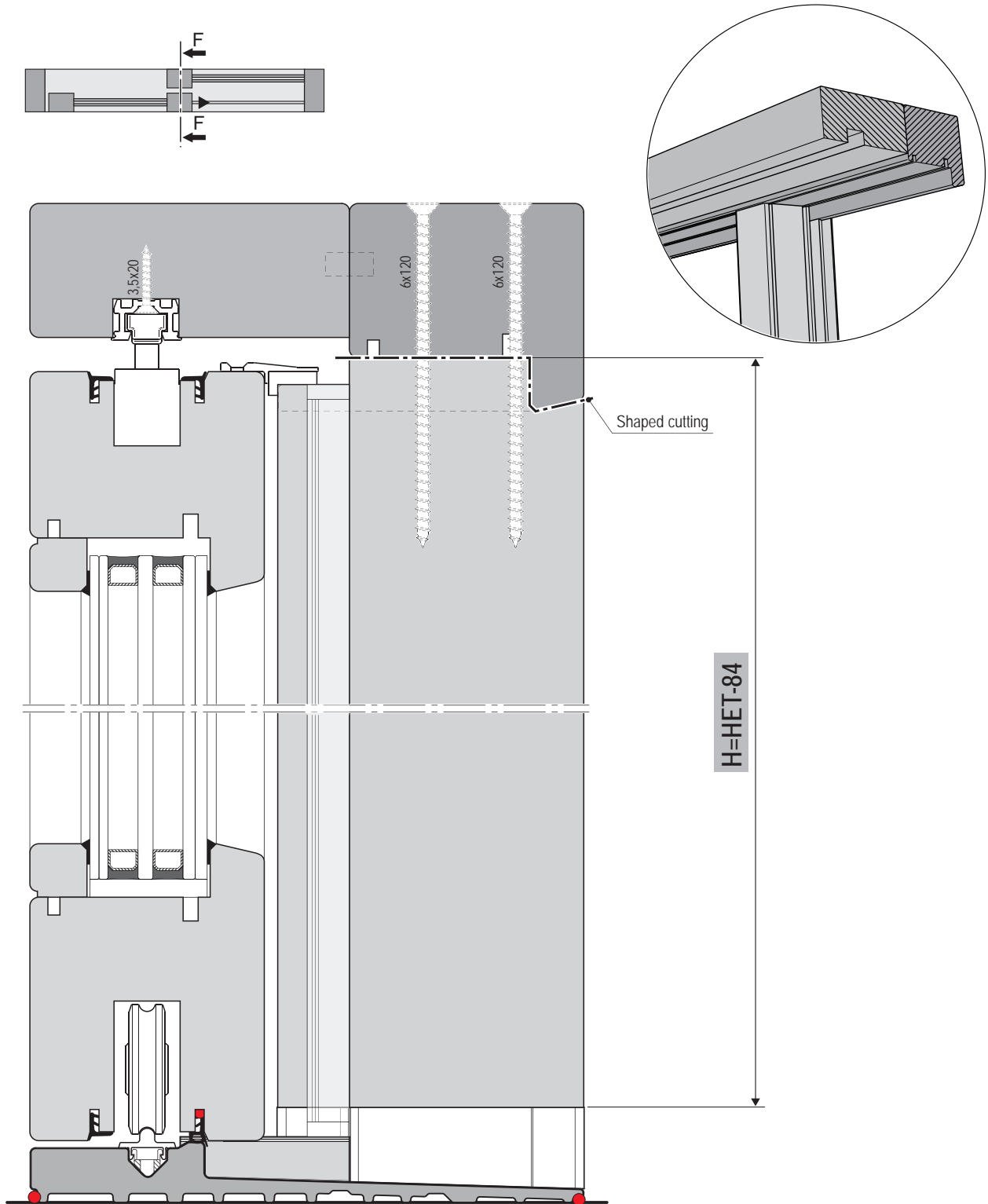

Wood detailing: vertical section- Layout A

Scale 1:1



The glazing bead dimensions and the lower termic profile suppose the use of a 41 mm glass shim.

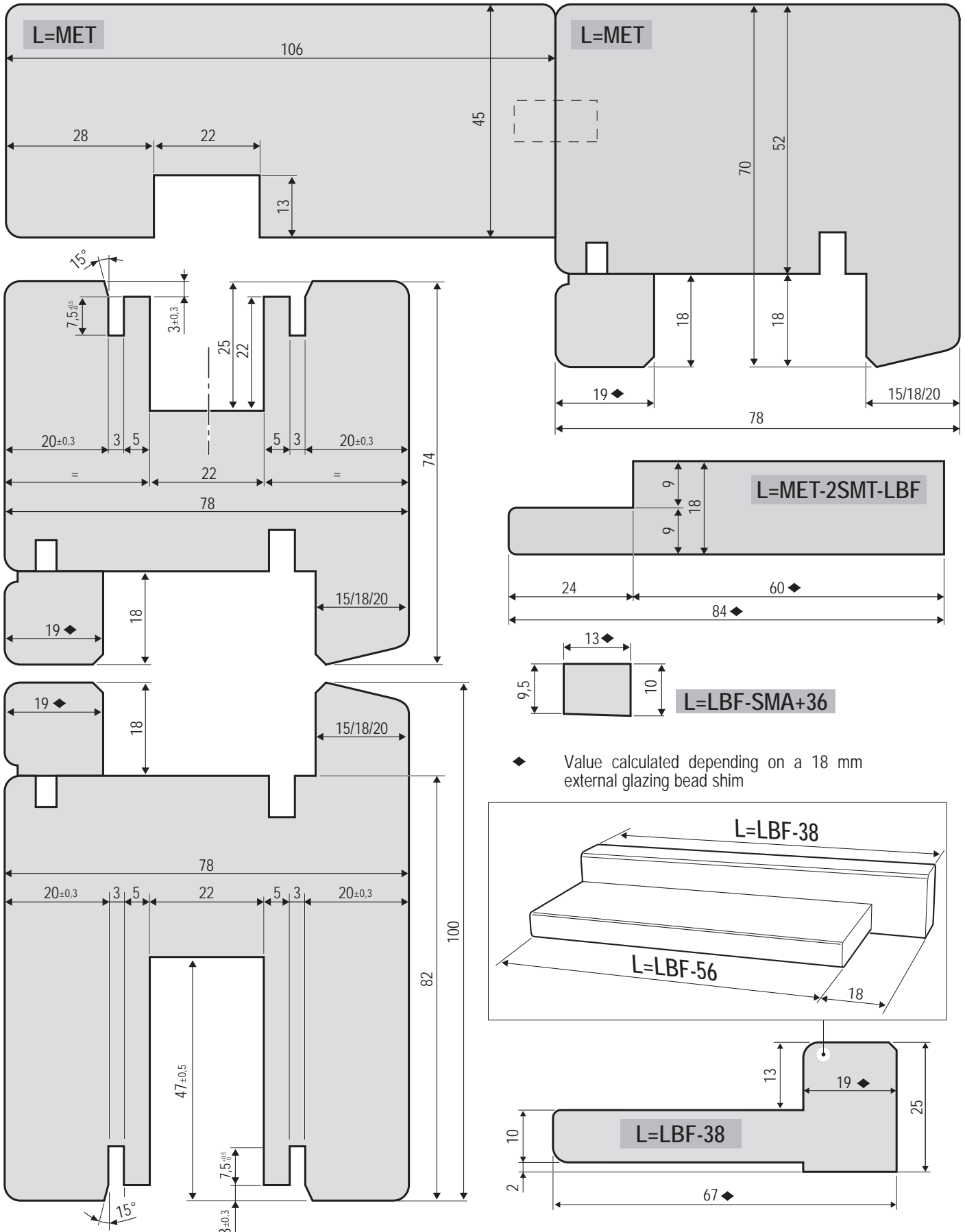

◆ Value calculated depending on a 18 mm external glazing bead shim

Central point horizontal section with coaxial sashes- Layout E



Layout E - 2 fixed sashes glass and 2 sliding doors

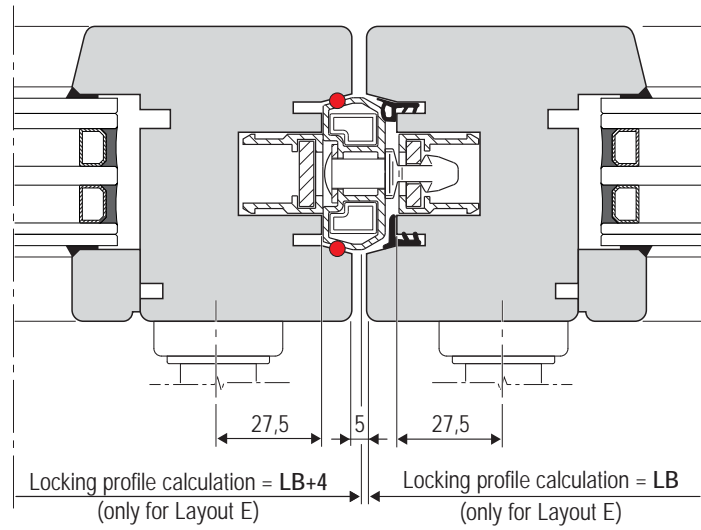

Wood detailing: central point horizontal section - Layout E

Scale 1:1



The glazing bead dimensions and the lower termic profile suppose the use of a 41 mm glass shim.

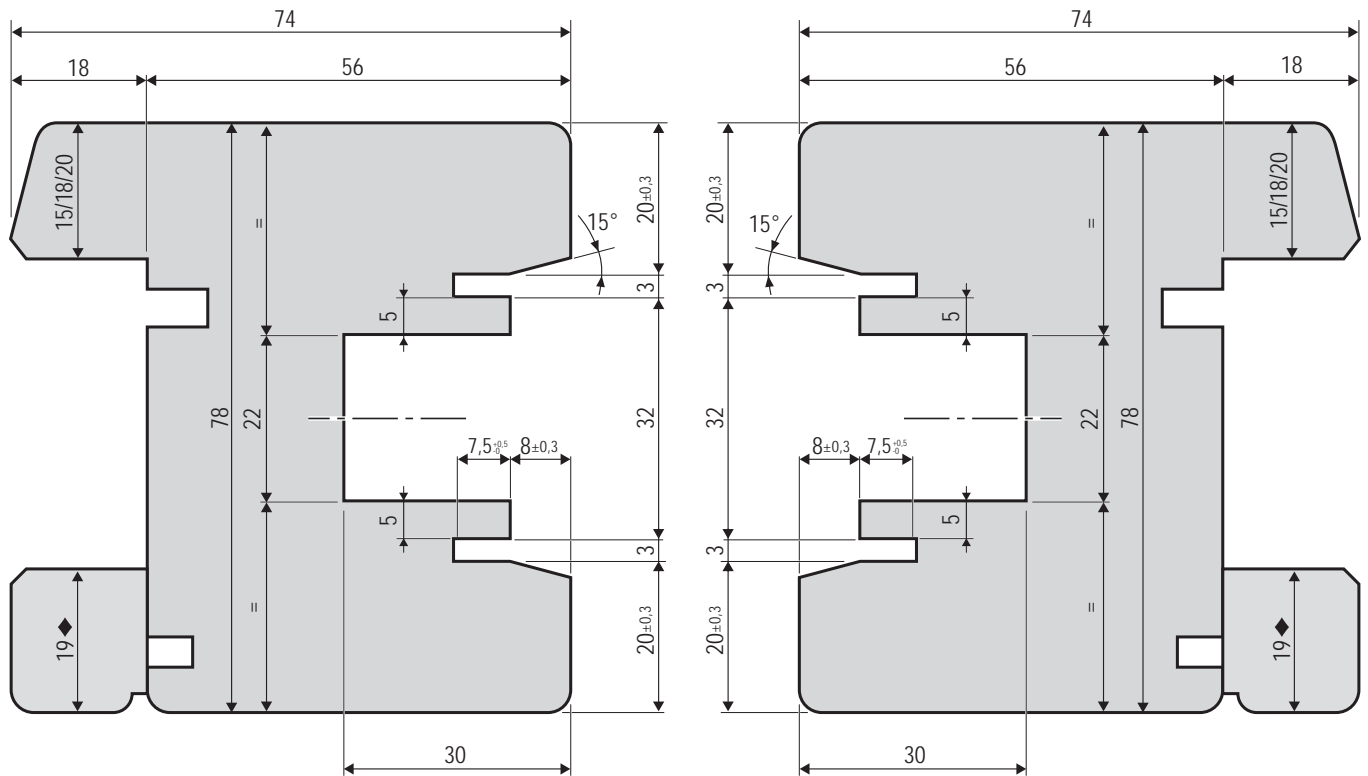

◆ Value calculated depending on a 18 mm external glazing bead shim

Central profile and beak on sliding sash positioning- Layout E

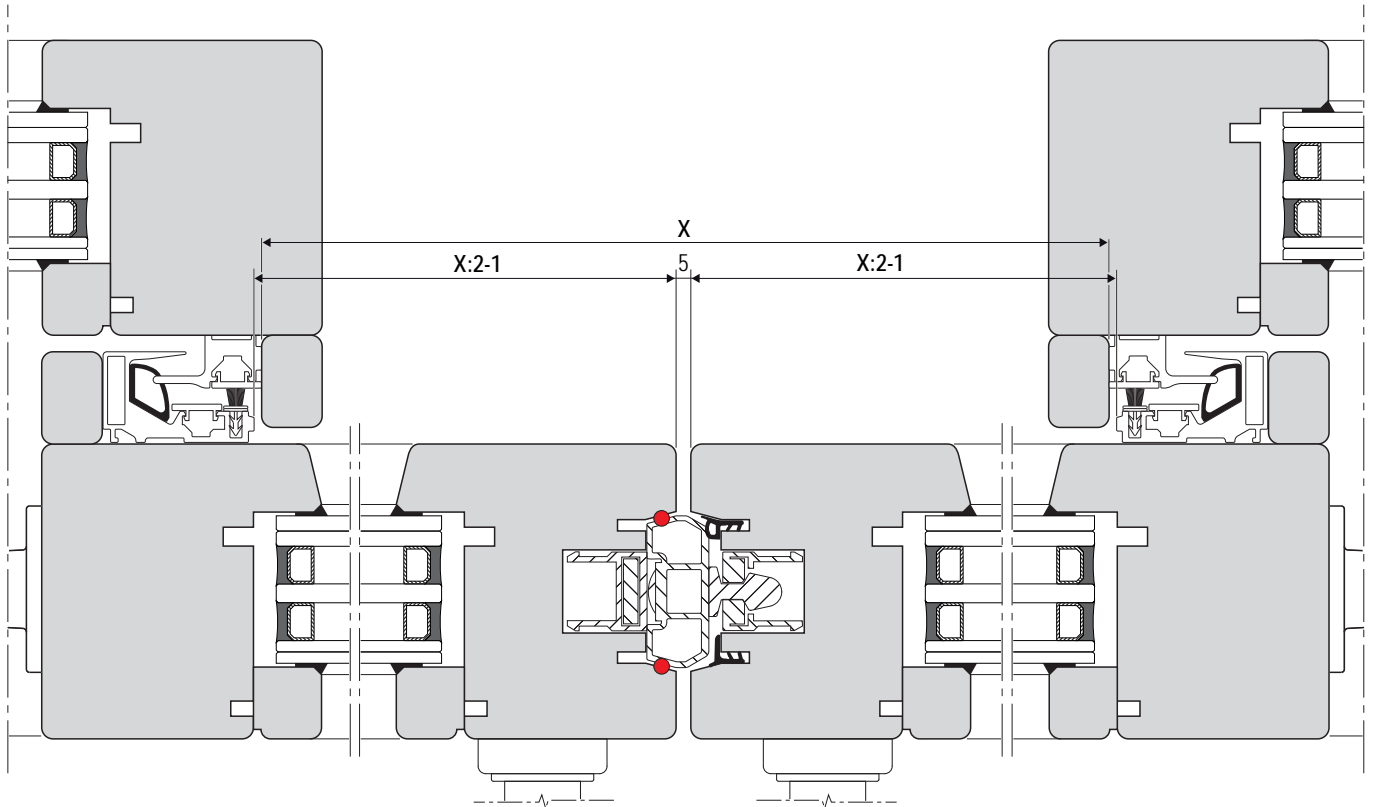

Locks hole realisation

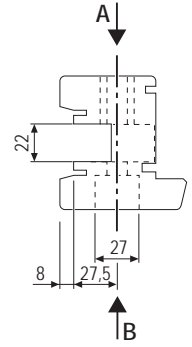
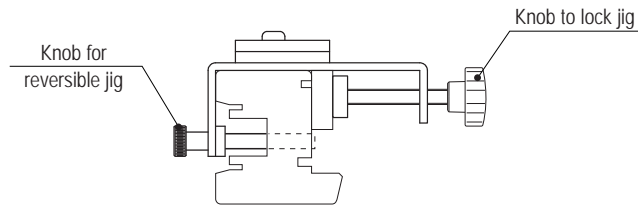

POSITIONING THE JIG

HANDLE HOLES

VIEW "A" - INT. SIDE

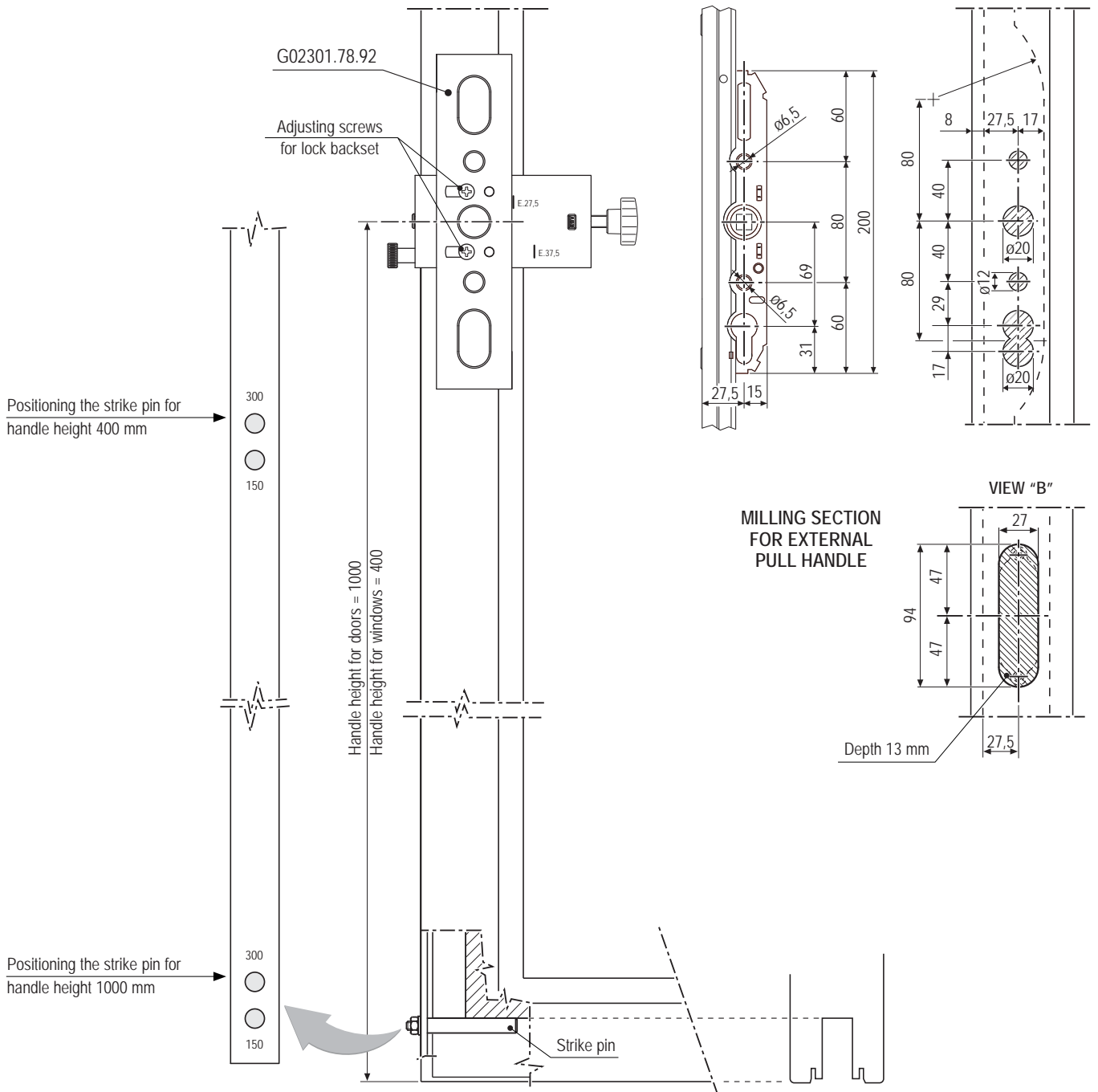

Mounting carriages, lock and accessories

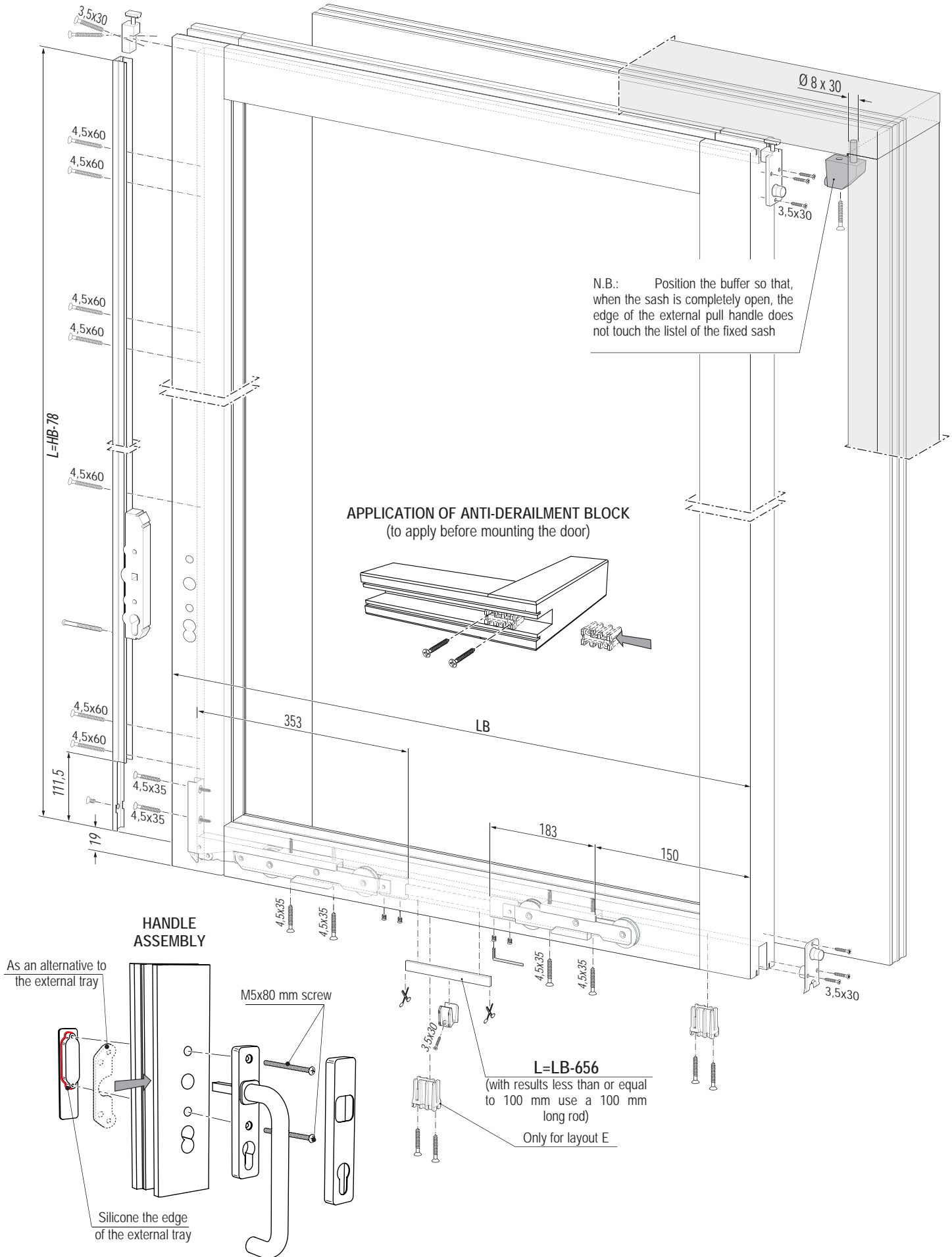

Sash assembly

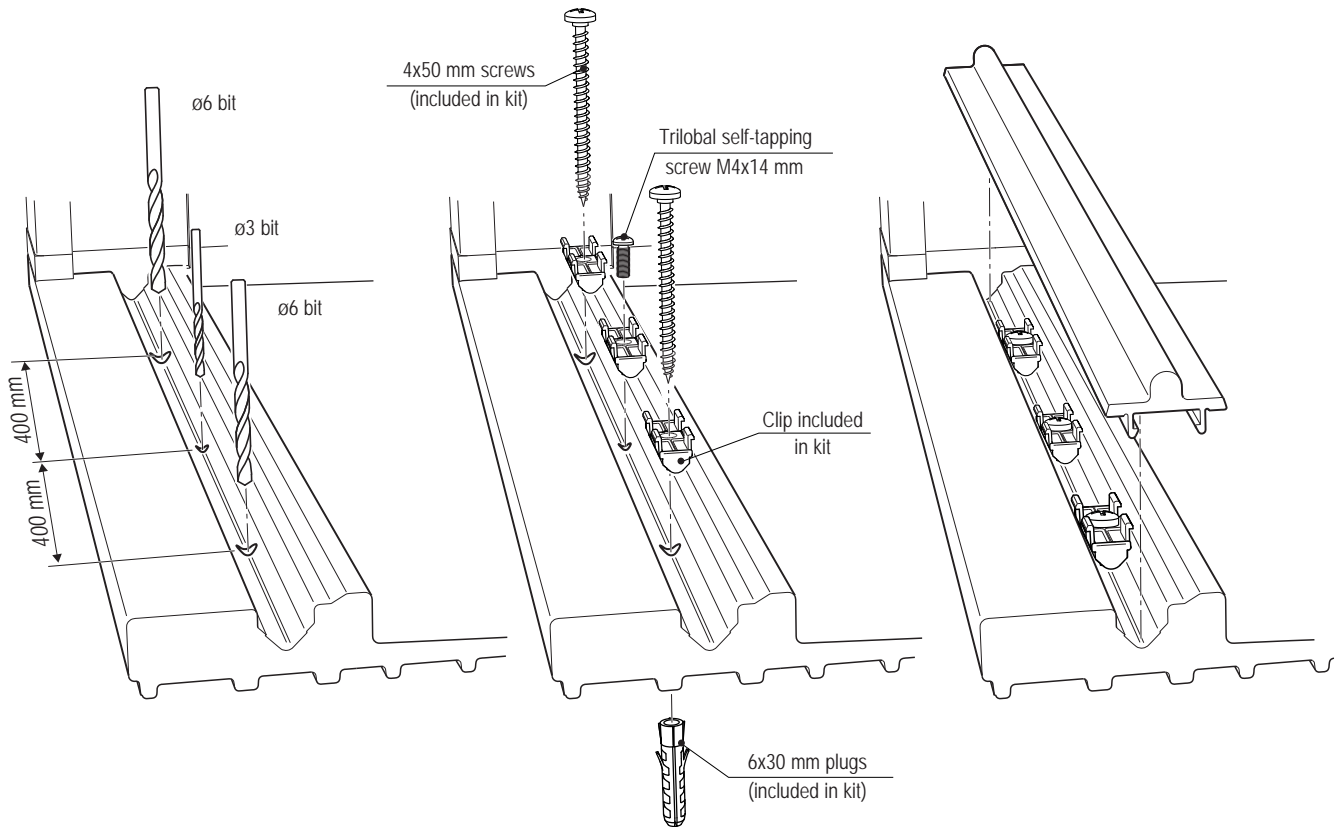

Ventilation striker application

JIG FOR VENTILATION STRIKER APPLICATION DETAIL

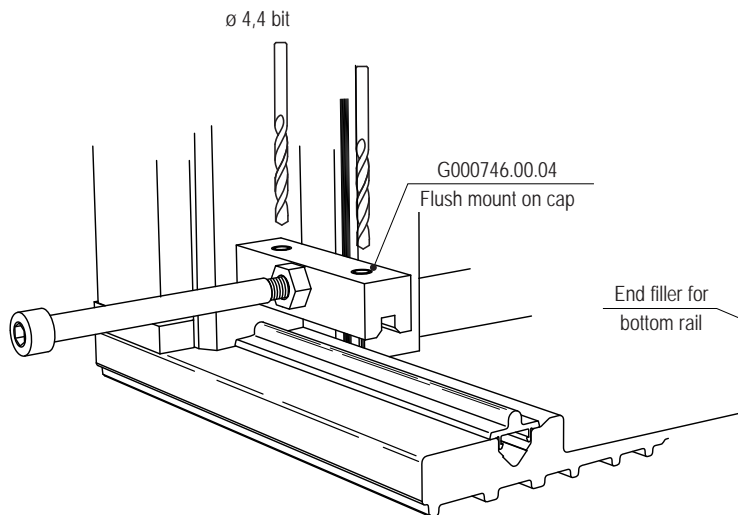

VENTILATION STRIKER APPLICATION DETAIL

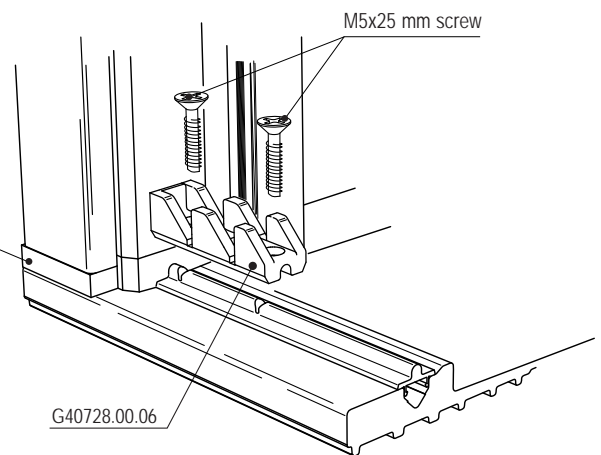

Positioning of the fixed sash glass

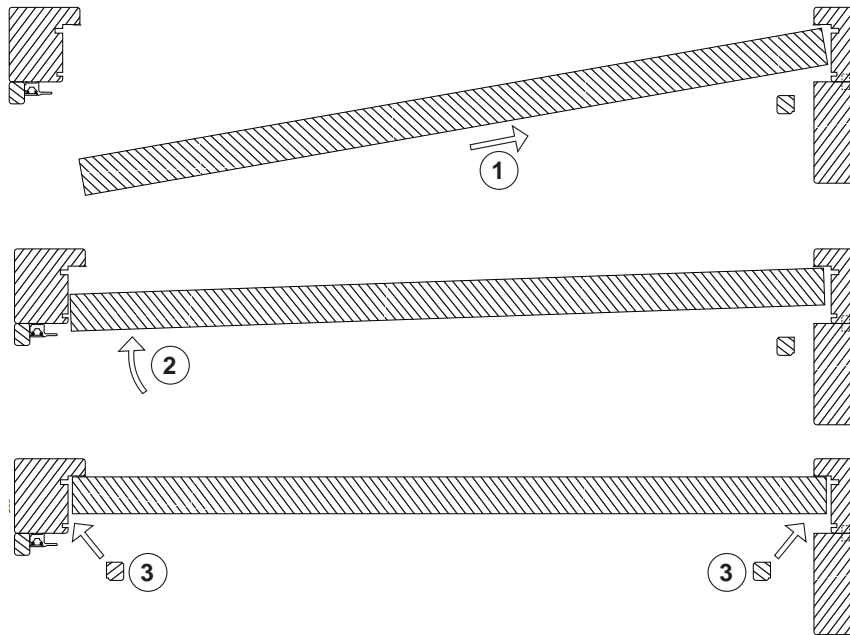

Sliding sash assembling

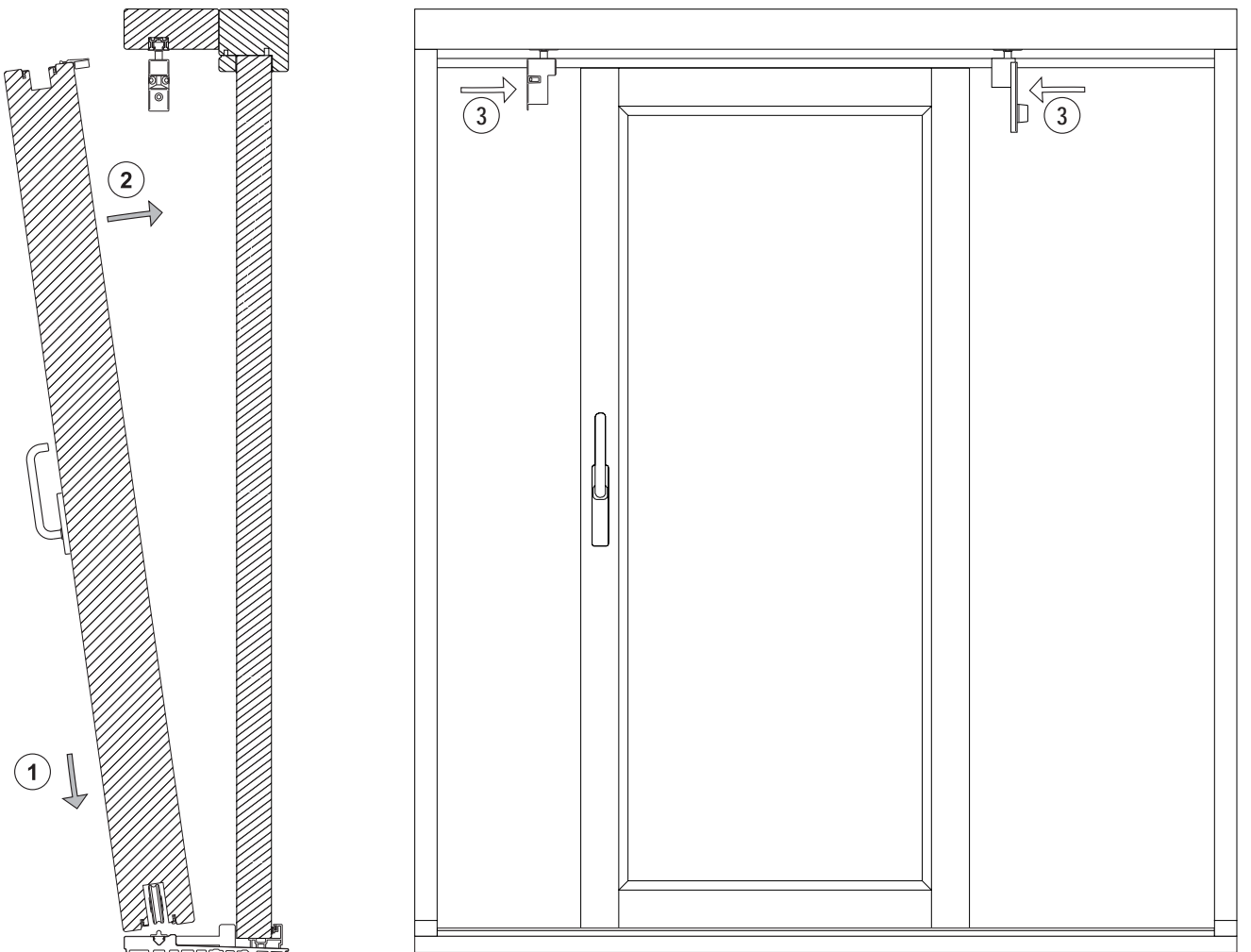

Locking pin mounting on wooden pin holder profile

PIN DISTANCE		
GR	A	B
1	450	-
2	850	-
3	980	1450
4	980	1600

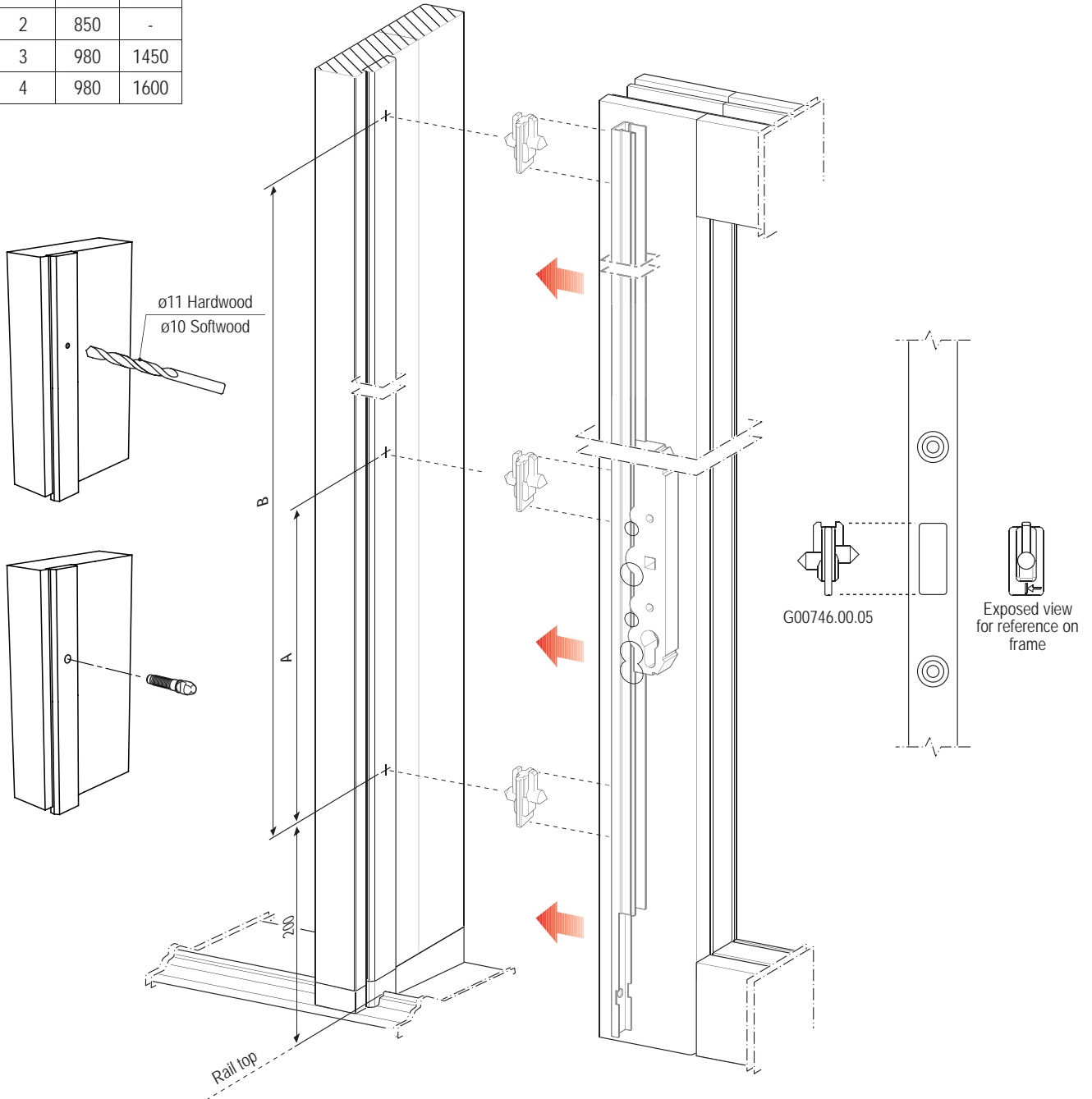

Particular locking profile for central point with symmetric coaxial sashes

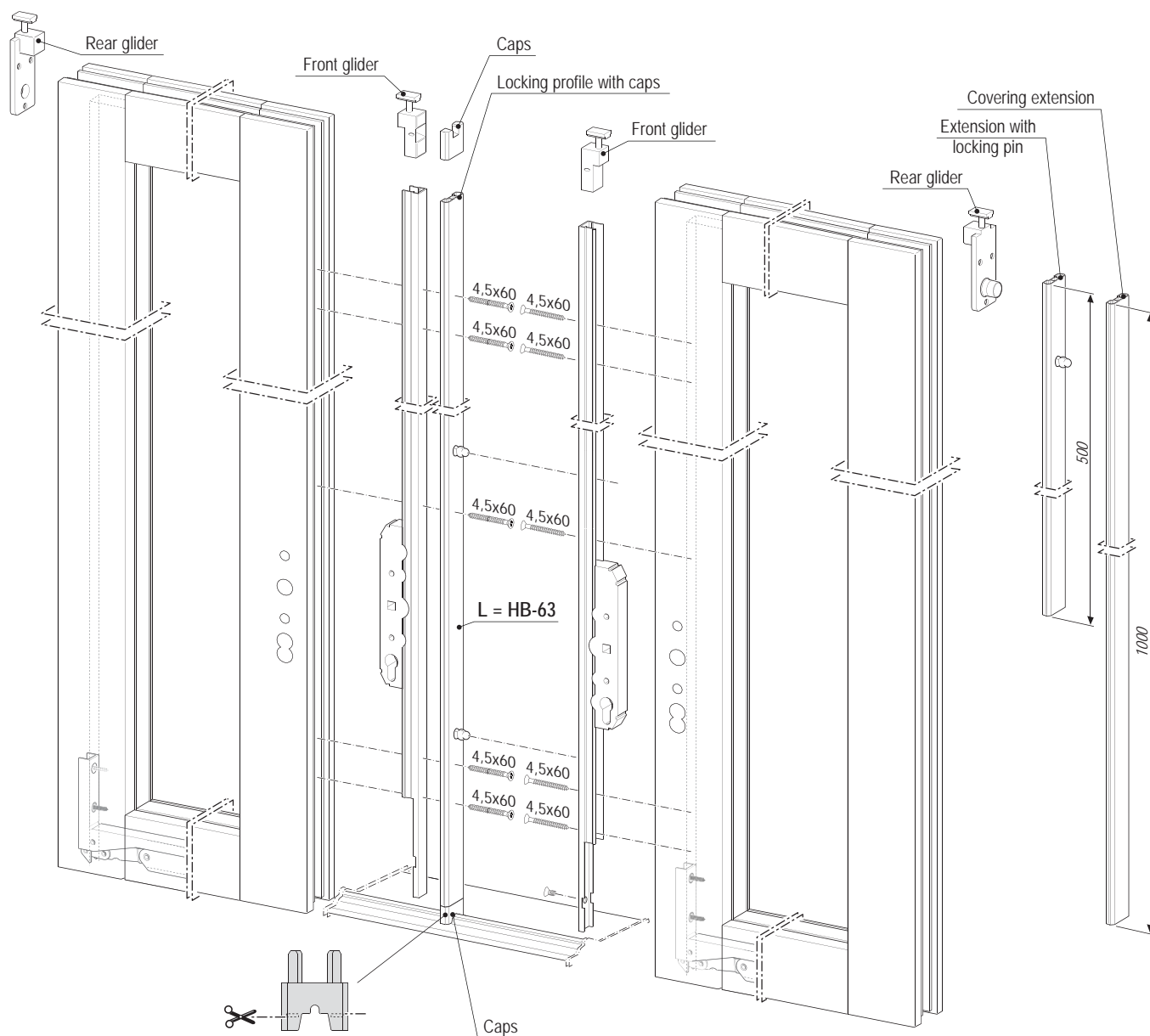



Steps to take for factory process control (FPC)

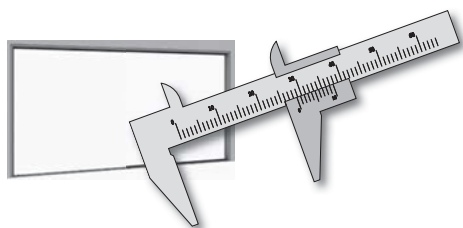

Frame component measurements and techniques for air-water tightness

- 1 - Notice the length and the width of the top transom and the vertical jambs
- 2 - Check that the width and depth of the milled housing for the aluminium top guide and the wooden strips are in accordance with the instructions included in this technical catalog.
- 3 - Check the length and the width of listels
- 4 - Check if the threshold length, snap-in rail and the glass holder correspond with the indications in this technical catalog.

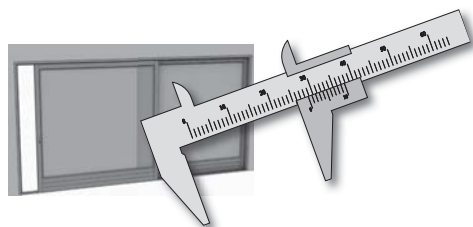

Sash component measurements and techniques for air-water tightness

- 1 - Based on the frame measurements, calculate, according to the instructions provided in the technical manual, the measurement of the sashes (LxH) and check that the dimensions of the sash produced correspond to those calculated.
- 2 - Check the orthogonality (square) of the sashes by measuring the diagonals: it is very important that they are the same for correct operation and closing.
- 3 - Verify that the thickness of the sash is exactly 78 mm.
- 4 - Check the width of the milling 22x47 mm for the carriage embedding and control they are exactly in the middle of the 78 mm shim.
- 5 - Check depth and width of the milling to the gaskets embedding and control the status in order to avoid dirty and remaining glue/varnish.
- 6 - Check the depth and position of the lock hole.
- 7 - Check the coplanarity of the bottom jamb/transom joints of both leaves. Level with stucco if required, in order not to compromise the seal.
- 8 - The double glazing sheets should have silicone applied on both on the rebate support as well as around the outer perimeter, on the wooden frame and the aluminium glass holder profile.
- 9 - Silicone the internal glazing beads or use the specific gaskets.
- 10 - Apply a silicone bead inside the groove for the bottom outer gasket before inserting it.



Alban Giacomo SpA

Headquarters:

Via A. De Gasperi, 75
36060 Romano d'Ezzelino
(Vicenza) Italy

Warehouse:

Via Col Beretta, 4
36022 Cassola (VI)

Cylinders plant:

Via S. Bortolo, 44
36020 Pove del Grappa (VI)

Tel. +39 0424 832 832

www.agb.it - info@agb.it